

REX AUTOMAT CLASSIC / FUTURA

The continuous dough dividing and rounding machine

Execution: 4 to 6 rows

Weight ranges: 20 - 160 g

Hourly capacity: up to 9000 pieces



THE BETTER SOLUTION

Operating principle

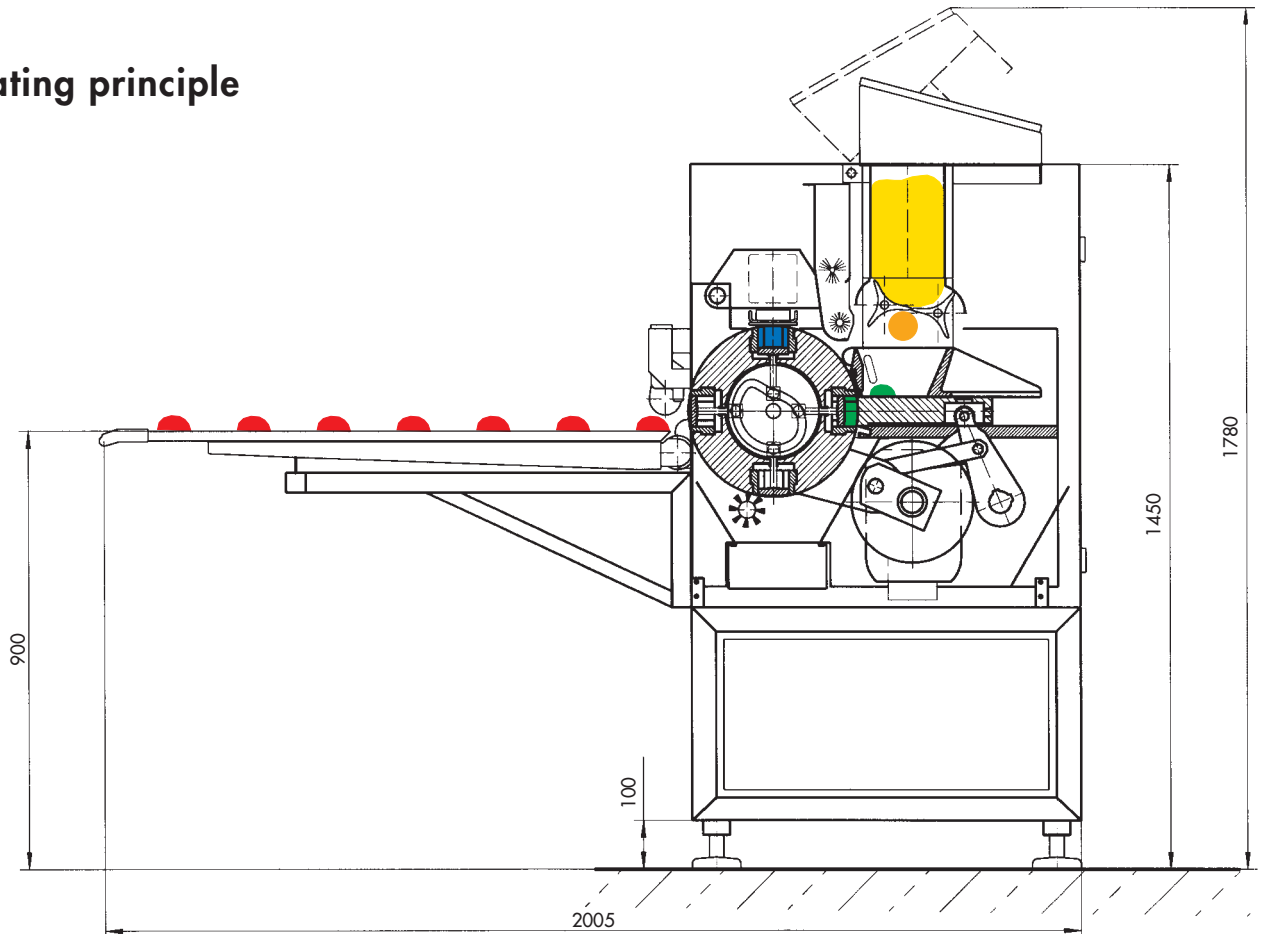

- **gentle dough infeed:** Choose from our wide customised dough hopper programme, from the standard dough hopper with a capacity of approx. 12 litres to a large dough hopper with a capacity of approx. 240 litres
- the **pre-portioning** of the dough is controlled by means of our patented dough infeed system consisting of dough infeed star rollers, dough level sensor and hopper duster
- **gentle dividing** of the dough pieces (dough dividing) according to the well proven **Rex-High-Soft-(HS)-system** by means of a spring protected dough pusher and a cam controlled dividing piston. The excess dough is recycled with hardly any mechanical pressure.
- the **rounding** of the dough pieces occurs in the piston cylinders after the drum has rotated by means of a special rounding plate which is similar to that of a plate rounder. During the rounding process the rounding height is adjusted automatically. Selection of a different dough weight results in an automatic adjustment of the rounding height.
- **discharge** of the dough pieces: after each turn of the dividing drum the dough pieces are discharged from the piston cylinders by means of dividing pistons and are transferred to the following spreading finger belt with the required seam position.

REX AUTOMAT FUTURA - *the extremely versatile machine*

The most important feature of this machine is its enlarged dividing drum with 8 rows of dividing cylinders located around the outside of the dividing drum and equipped with dividing pistons of different shapes and sizes.

Switching between the two dividing pistons occurs electromechanically by pressing a button and does not interrupt the operation.

The double chamber principle offers the following advantages:

- considerable extension of the weight range
- possibility of so-called "RUSTIKA" pistons for the production of angular, country-style bread rolls
- possibility of special pistons, e.g. for American Cookies

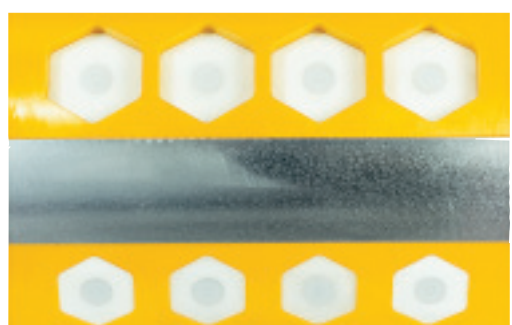
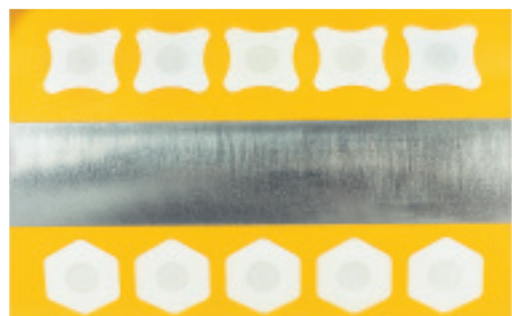

REX AUTOMAT CLASSIC II

Weight range

Execution

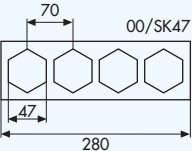
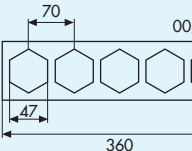
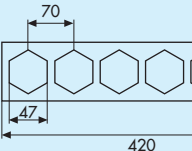
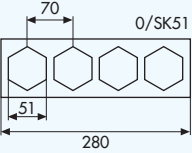
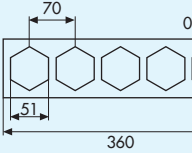
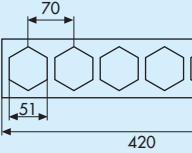
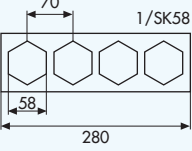
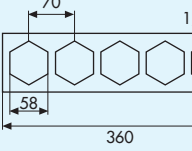
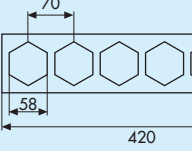
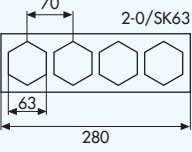
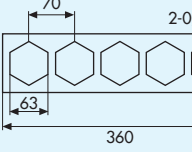
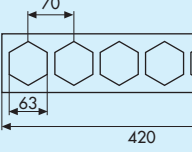
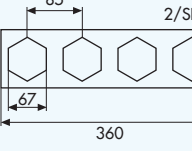
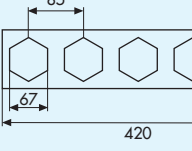
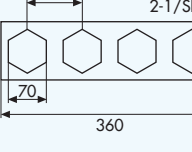
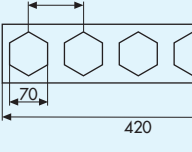
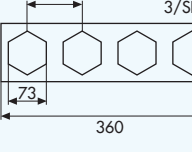
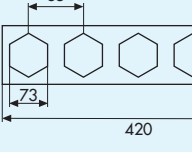
Size	g	6000 pieces 4 rows	7500 pieces 5 rows	9000 pieces 6 rows
00	20-50			
0	22-55			
1	35-85			
2-0	50-110			
2	55-125			
2-1	60-135			
3	65-160			

This table only includes the most common models. The weight ranges depend on the dough feed and consistency and may therefore increase or decrease. INDIVIDUAL special weight ranges upon request.

REX AUTOMAT FUTURA Examples

Model	Rows	Weight range (depending on dough)	Piston size (for rounding)	RUSTIKA-piston (for dividing)	Hourly capacity
Futura	4	35 - 125 g	SK58 + SK67		6000 pcs.
T4 S-	4	35 - 85 g	SK58	59 or 61 or 64 mm	6000 pcs.
MKB	4	55 - 125 g	SK67	59 or 61 or 64 mm	6000 pcs.
Futura	5	35 - 125 g	SK58 + SK67		7500 pcs.
T5 S-	5	35 - 85 g	SK58	59 or 61 or 64 mm	7500 pcs.
MKB	5	55 - 125 g	SK67	59 or 61 or 64 mm	7500 pcs.
Futura	6	35 - 85 g	SK68	55 or 59 or 61 mm	9000 pcs.
T6 S-					
MKB					