

Ultra



Inclined Moulder

Use

The Moulder Ultra is a destined machine to fashion and lengthen the let us suffer as a result, and suiting all sorts bread (sticks, buns, country etc. ...).

With its variants and options, it can be set up on one foot, with dough rest, table and output conveyor, and is perfectly compatible with DELTA semi-automatic and automatic pre-fermentation units. The dough is centred by the feed channel and rolled between three non-stick cylinders. It is then gently and gradually stretched between two soft-surface belts turning in the opposite direction. When stretched, the dough are placed on a soft-surface sliding shelf (Ultra Manu model).

The machine is made easier to use by keeping control and safety functions close together. It is electronically adjustable by a membrane keyboard. Its low noise level (58 dBA) makes for quiet operation.

Construction

- Cast steel frame
- ABS casing
- Grooved belt drive
- Quiet running
- Moulding belt 100 % pure wool treated with water repellent
- Adjustable rolling thickness
- Manual functions
- Automatic operation with 35 programs
- Electronic control of the length of the dough
- Supply voltage : 230 V 50 Hz

Machine complies with  regulations



Model with manual loading

Reference	Model
29800511	Ultra Manu Control on the left
29800521	Ultra Manu Control on the left and system for pointed ends loaves
29800531	Ultra Manu Control on the right
29800541	Ultra Manu Control on the right and system for pointed ends loaves

Model with automatic loading

29800551	Ultra Auto Control on the left
29800561	Ultra Auto Control on the left and system for pointed ends loaves
29800571	Ultra Auto Control on the right
29800581	Ultra Auto Control on the right and system for pointed ends loaves

Options

Reference	Description
29800631	Felt drying fan (can not be sold separately)
29800641	Germicide lamp (can not be sold separately)
	Control at distance

Accessories

Reference	Description
29800611	Stand with castors
29800601	Stand packed with 6 wooden planks



32, route de Wolfisheim - F-67810 Holtzheim
Tél : 33 (0)3.88.78.00.23 - Fax : 33 (0)3.88.76.19.18
www.bongard.fr - bongard@bongard.fr

Ultra Moulder

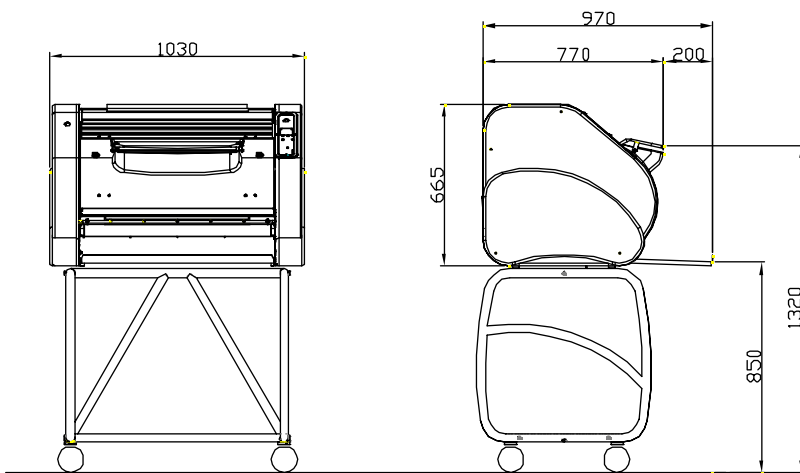

General features

Model	ULTRA	
Reference		
Possible combination on stand, table, first proofer	yes	
Electrical control	yes	
Dough piece loading	Manual	yes
	Automatic	yes
Safety dev	touch bar	yes
Feed conveyor	no	
Dough piece out-feed	on trays	yes
	on out-feed belt	yes
Performances	1800 p / h	
Dough piece weight (Mini to Maxi)	40 - 1500 gr	
Motor power	0,75 kW	
Dimensions and weight		
Width x depth	1030 x 770 mm	
Height	660 mm	
Loading height	1320 mm	
Output height	950 mm	
Net weight	210 kg	